No. 3

APPLICATION NOTE

Laser Diode Protection Strategies

Table of Contents

Introduction	1
Physics of Laser Damage	1
Laser Protection Strategies	2
LEVEL I Control Instrumentation	4
Current Sources	4
Temperature Controllers	9
Overview of Recommendations - Level I	10
LEVEL II System Setup	11
Grounding	11
Laser Mounts	15
Cabling & Shielding	16
Overview of Recommendations - Level II	18
LEVEL III Lab Environment	19
Electrical Fast Transients	19
Radiated Transients	19
AC Power Line Isolation	21
Overview of Recommendations - Level III	22
LEVEL IV Laser Handling	23
Electrostatic Discharge	23
Other Handling Precautions	24
Overview of Recommendations - Level IV	25
Summary	25
Laser Protection Checklist	26
References	27
Sidebar: What is a “Ground Loop”?	13
Sidebar: Radiated Transients - How are they Coupled?	20

Protecting Your Laser Diode

By Doug Hodgson and Bill Olsen

Recommendations and use the checklist to minimize your risk of laser damage.

Physics of Laser Damage

Under ideal conditions, laser diodes can demonstrate excellent reliability, with lifetimes exceeding 100,000 hours. However, they are extremely sensitive to electro-static discharge, excessive current levels, and current spikes, or transients. Symptoms of damage include reduced output power, shift in threshold current, change in beam divergence, difficulty focusing to previously-attained spot sizes, and ultimately failure to lase (LED-like output only).

Semiconductor injection lasers can be damaged by a variety of mechanisms. Many factors, including wafer growth procedures, device fabrication, and operating conditions determine which mechanism is dominant. The primary concern of this application note, however, is catastrophic facet damage (CFD) and latent damage resulting from electrical transients or other mechanisms related to handling and operating conditions.

To understand CFD, consider that the size of the emitting region of a typical 5 mW laser diode is about 2 μm by 4 μm . This equates to a normal optical power density of 625 W/mm². Damage can occur when the optical energy densities at the output facet exceed 10⁴ W/mm². This may seem like a sizable “margin of error” — until surface absorption effects are considered.

In the pumped part of the active region, gain is greater than loss, and the material is trans-

parent. At the facet surface, however, non-radiative recombination causes the material of the active region to become absorbing. At high energy densities, temperature rises faster than normal. This temperature increase causes greater absorption at the surface resulting in even greater temperatures. This thermal runaway melts the mirror facet and/or facet coating, resulting in gross crystal faults in the interior of the laser, and pits at the surface. (Figure 2)

Typical laser diodes have rise times in the 80 ps range. Mirror damage is the most rapid form of laser degradation, and the destruction of the laser mirror can be virtually instantaneous. Laser diodes are therefore very sensitive to fast overshoot events, such as

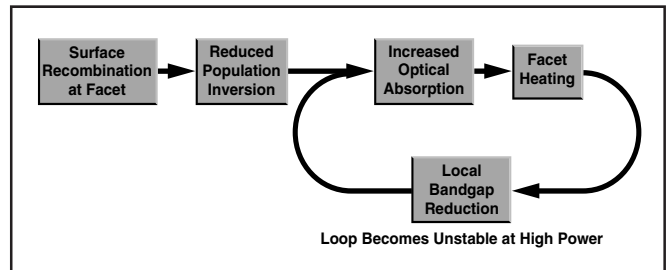

Figure 1. Thermal runaway at laser facet will result in catastrophic facet damage.

brief electrical transients and electrostatic discharge (ESD), as well as DC over-current.

Most transients in today’s laboratories carry energy in the high-frequency spectrum. Since laser diodes are so responsive at these frequencies, they are easily damaged by transients with relatively little energy content.

Worst of all, data first collected at British

Telecom Research Laboratories indicated that high-frequency transients too small to cause catastrophic damage may result in latent damage, leading to premature failure under actual working conditions. Lasers damaged in this way are obviously a serious liability in applications requiring long lifetimes. (You'll

notice that much of the protection strategies discussed in this application note focus on the prevention and attenuation of high-frequency transient energy.)

Laser Protection Strategies

Our ongoing studies of laser diode protection and electrical transient effects have taught us a great deal about the nature of (and coupling mechanisms of) electrical transients. The results of these studies, combined with information from laser manufacturers and experts in the fields of laser damage, ESD, and EMI, have led to the concept of "multiple-tier laser diode protection". These tiers, or levels, are illustrated in Figure 3.

These levels have been created to highlight principle areas of concern. As we'll see, these levels of protection are organized by the damage mechanisms against which they are intended to protect. The order of these protection levels is not intended to imply relative importance. In fact, human-contact ESD (Level IV) is arguably the greatest cause of premature laser failure.

The following sections present the four levels of protection in greater detail. Note that these

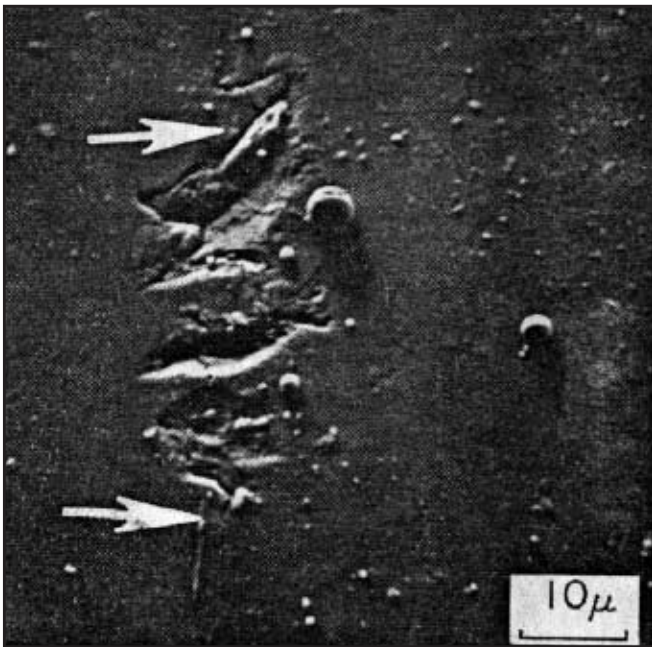

Figure 2. Scanning electron photomicrograph of a catastrophically damaged laser facet showing fractures (pits) and droplets. The arrows show the location of the p-n junction. (Ref. 6)

4-Tier Laser Protection Strategy

LEVEL	Description	Damage mechanism
I	Instrumentation (Current source, Temperature controller)	Over-current, overheating, power line surges and spikes (transients)
II	System setup (Cables and mounts, Proper grounding, Shielding)	Radiated electrical transients
III	Lab environment, Power line conditioning, Other instruments	Severe fast transients
IV	Laser packaging, Handling, and Human contact	Electrostatic discharge (ESD), Foreign-matter contamination

levels are analogous to proverbial “links of a chain.” To ensure thorough laser protection, and minimize the risk of laser diode damage, all levels of protection must be carefully implemented. A single “weak link” in protection can negate the time and investment made at other levels. At the very least, familiarize yourself with the summaries presented at the end of each section. For your convenience, a checklist of specific action items is presented at the end of this document.

LEVEL I Laser Control Instrumentation

The instrumentation you use to control your laser diode should be designed with appropriate protection topologies and AC-line transient suppression. As a minimum, your drive instrumentation must: 1) include an independent adjustable limit of the drive current, 2) prevent reverse bias of the diode junction, 3) suppress electrical transient spikes from the AC power line, and 4) certainly not produce its own current transients.

When used, thermoelectric temperature controllers should at least prevent TE module damage by providing a current limit. Firmware temperature limits and appropriate control algorithms (which prevent thermal oscillations) are also recommended.

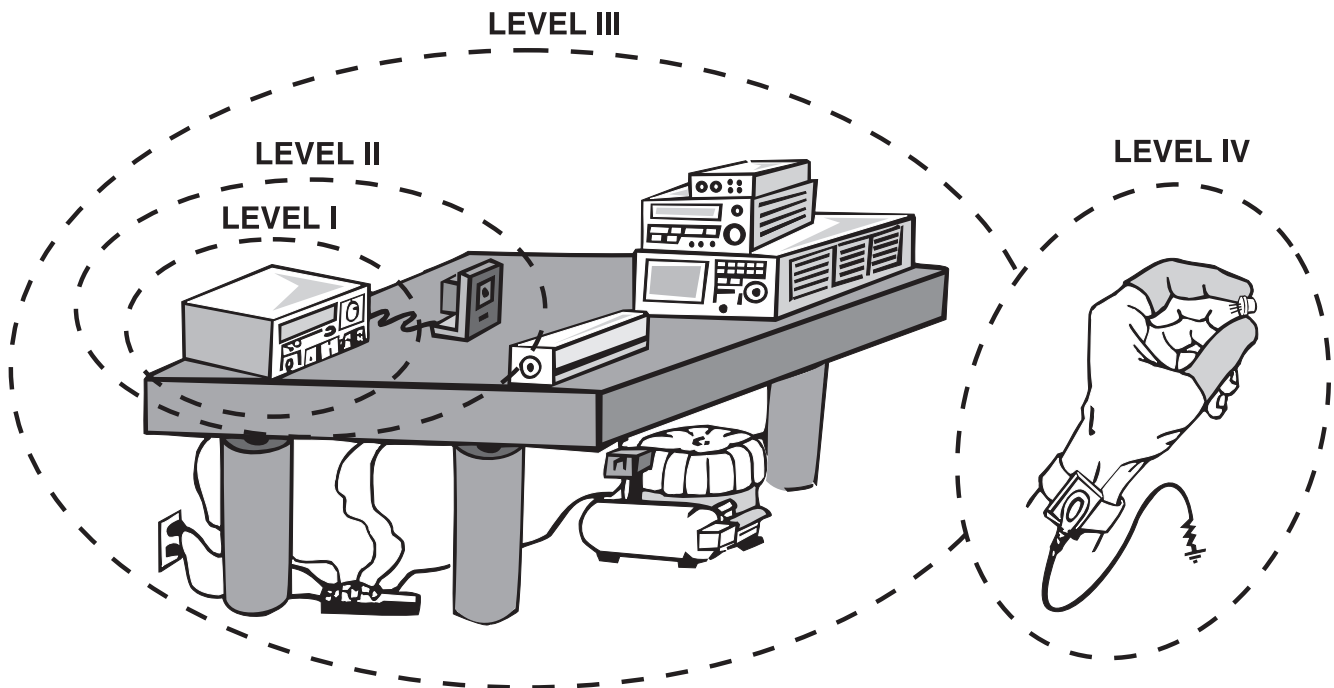

Figure 3. Multiple levels of laser diode protection. All levels must be fully implemented to ensure adequate defense against damage.

Making a small investment in time and effort to choose the right instrument for your needs can easily save time, money, and frustration



in the long run. The following sections outline some of the features you should look for while selecting laser control instrumentation.

Current Sources

Since a semiconductor laser is inherently a current device, a true current source is recommended for driving laser diodes. Typical voltage sources (bench power supplies) carefully ramp voltage at turn-on, but current is not controlled. In fact, a capacitor is frequently placed across the output of voltage sources to hold the voltage “stiff.” Unfortunately, this allows the current to change quickly for changing loads, putting the laser at risk.

In short, a voltage source simply cannot provide the same level of control as a true current source. Direct control of current allows for precise linear control of laser diodes over a wide range of impedances. Unlike a voltage source, the current will not increase if the circuit reaches the compliance voltage limit.

Unfortunately, current control is not without its own design challenges. When current is

directly controlled with a feedback loop, the loop response must be controlled to avoid overdrive of the output in response to an input step. To provide an adequate level of laser protection, full control of the current-source loop is required at all times. The circuits described below provide these controls. Make sure your laser driver has been tested to provide the necessary topologies.

Shorting Output

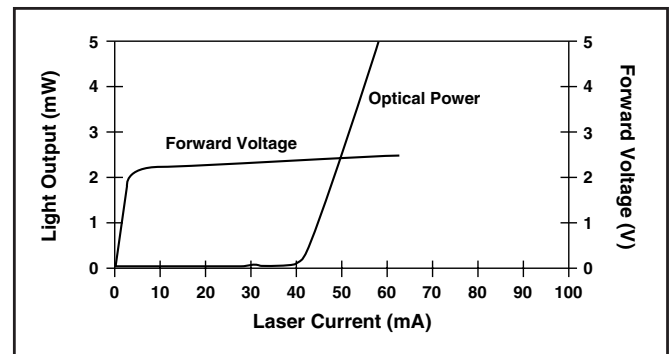

Figure 4. Optical output power and voltage vs. drive current of a typical laser diode. A laser diode is inherently a current device, and voltage supplies offer little control at best.

The laser driver you choose should maintain the output leads at the same potential while the laser is not being operated. ILX current sources have a shorting relay across the output that maintains the laser leads at the same potential. Until the output is turned on, the shorting relay remains closed. The relay provides shorting protection even if the power to the instrument is off. This “shorting output” provides safety against ESD damage while the laser is connected to the instrument.

Be aware that some laser instrumentation utilizes FETs for output shorting. These transistors are active only when the instrument is powered-up. In such cases, you should

turn the instrument on (and leave the current output turned off) during laser connection or installation.

Slow-Start

To protect against turn-on transients, your laser diode driver should feature a slow-start circuit that guarantees an overdamped turn-on response. All ILX Lightwave precision current sources gradually open their shorting circuits during turn-on, allowing current to be slowly sourced to the laser. Current is held from the output until the control circuits are fully active and all circuit transients have “died out”.

To prevent instrument turn-on transients, start-up times longer than 100 msec are sufficient. However, the US Federal Government requires laser systems to include a minimum 2 second turn-on delay for personal safety (CDRH US21 CFR 1040.10). This should not be confused with a slow-turn-on protection strategy. Your laser driver should include both features.

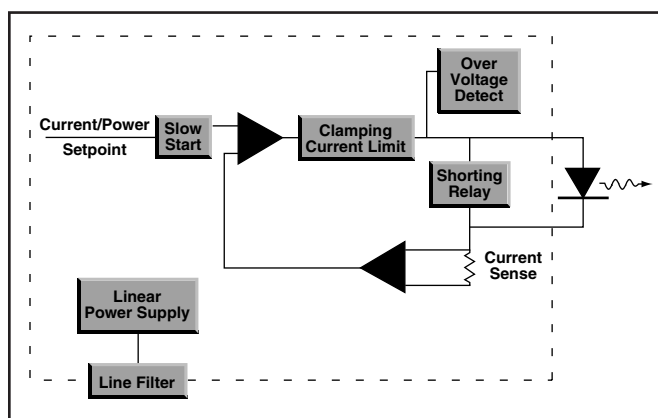

Figure 5. Functional block diagram of a typical ILX Lightwave precision current source topology. Note laser protection features.

Current Limit

Since laser diodes are sensitive to excessive drive current, the need for an independent current limit feature is critical. Accidental excess drive current will result in instantaneous overheating in the laser, and melt the mirror facet and/or facet coating.

Unfortunately, current limit is often poorly implemented by manufacturers of laser drivers. Unlike some products, ILX Lightwave current sources provide an exclusive clamping limit. Not only does this provide for protection against over adjustment of the setpoint current, it also limits drive current during analog modulation and constant-power operation. (Figure 6)

The implementation of a current limit will determine its effectiveness in non-DC modes of operation. In most limit topologies, the control loop actually switches from linear to nonlinear control as it moves in and out of limit. Depending on the time response of the limit circuit, some transient can be expected. Proprietary circuit topologies developed at ILX Lightwave have eliminated this transient in constant-current operation.

Set your current limit just above the operating current. ILX Lightwave current limits may be adjusted even while the laser is in operation, if the need for higher drive current arises. Keep the limit below the specified maximum-current rating provided by the laser manufacturer.

Over Voltage Protection

If a simple current source is forced to drive a high impedance load, its current control loop will saturate, and it will be unable to drive to

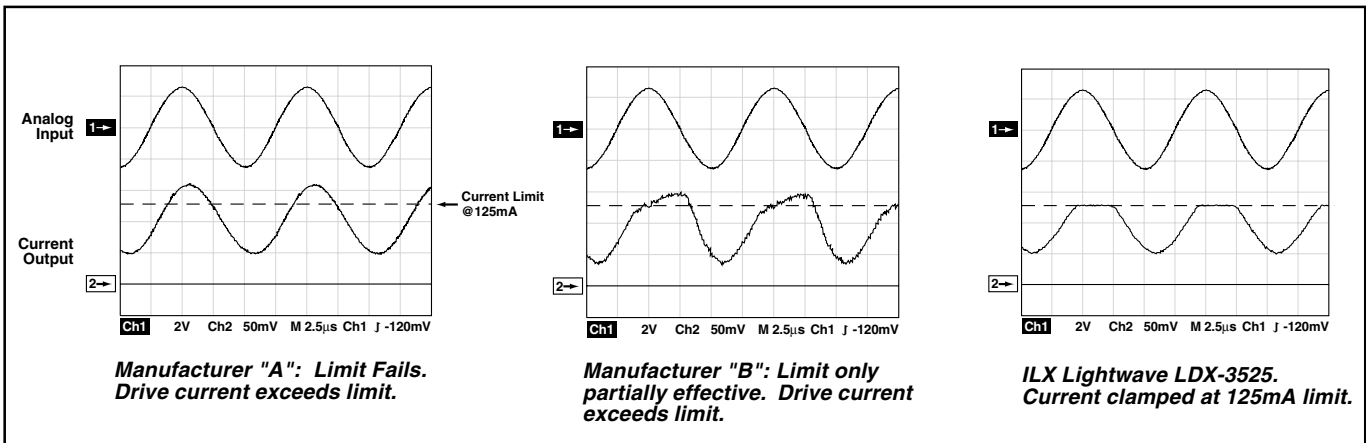

Figure 6. Your laser diode driver should utilize a clamping limit topology to prevent overdrive. (Signal 1: Analog modulation input. Signal 2: Instrument output current. From ILX Lightwave Technical Note #TN-3525-3)

the required (set) current. Furthermore, if the impedance is suddenly reduced, the control loop will drive the output current to the short-circuit limit. The laser will be overdriven until the loop feedback can adjust the control circuit and reduce the drive voltage. Although brief, this overdrive is generally sufficient to damage the laser. Your laser driver should protect against this condition by turning off the output stage if the control loop is saturated.

We realize that laser diode impedance usually changes slowly, and it's useful for you to be aware of this condition prior to the protective shut-off. Consequently, ILX Lightwave precision current sources have been designed with a two-stage overvoltage indicator. The first stage indicates when the upper control range is approached. If the control loop becomes saturated, the second stage shuts off the output to protect the laser from overcurrent. This two-stage trigger protects the laser, while providing a useful indication if the compliance voltage of the loop is reached.

Power Line Transient Suppression

AC line transients have become practically ubiquitous in today's laboratories. These transients arise from a wide variety of sources. High-voltage surges (caused by lighting or poor power conditioning) have always been a problem for users of laser diodes. In addition, electronic fast transients (EFT's) are becoming increasingly prevalent with the widespread use of computers and other electronic equipment that employ switching power supplies. (See "LEVEL IV, Lab Environment")

No instrumentation can prevent transients that are radiated directly onto the laser or drive cables. Nevertheless, the driver must suppress transients that reach its power input stage, and prevent direct coupling through the instrument. Usually, a combination of input filters is used to achieve appropriate suppression.

An extreme isolation transformer provides the best transient suppression, but cost and size make it prohibitive for a standard current source. Typically, current sources use a simple capacitive filter on the rectifier circuit.



ILX Lightwave instrument designs are subjected to rigorous transient tests. Tests include suppression of 1000V fast-transients and power line surges. (See ILX Lightwave Technical Standard #LDC-00196.)

Additionally, an input line conditioning filter may be used. At ILX Lightwave we have tested various combinations of these filters. We have found that the capacitive filter works best when used in conjunction with a specially-designed, doubly-shielded power supply transformer. In tests of our current sources with a line transient generator, this combination of filters significantly reduced the output transient at the laser diode output. (See ILX Lightwave Technical Standard #LDC-00196, "Measuring Transient Suppression of Laser Diode Drivers".)

Constant Power Operation

Some current sources offer a constant optical power mode. When photodiode feedback is used to control the output to the laser, care must be taken to ensure the proper connections of the monitor photodiode. Many laser diode packages contain an internal photodi-

ode that is internally connected to either the laser anode or cathode. Figure 7 illustrates the recommended connections and shielding for various configurations of laser diodes and photodiodes with ILX Lightwave Current Sources. If reverse biasing is used (photoconductive mode), the bias supply should have a voltage which will not cause the common-mode voltage of the feedback inputs to exceed its specified maximum. Avoid using a reverse photodiode bias on a laser package with common photodiode and laser pins. (Most ILX Lightwave controllers provide an adjustable photodiode bias.)

At low operating temperatures, some laser diodes are capable of producing excessive output powers, even if the rated drive current is not exceeded. It's a good idea to set a power limit on your laser driver if one is provided. Don't rely too heavily on a power limit, however, since its accuracy is dependent upon the detector coupling efficiency and linearity.

Choosing a Laser Diode Driver

When selecting a laser driver, check to make sure it includes the features noted above. These features generally apply to all users. In addition, select a drive instrument with maximum current levels commensurate with your laser's operating current. (In other words, a high-power current source should not be used to drive a low-power laser. Certain parameters, including some types of transient suppression, scale with the maximum current of the instrument.)

Additionally, if you plan to run your laser in DC (continuous-wave) mode, choose a cur-

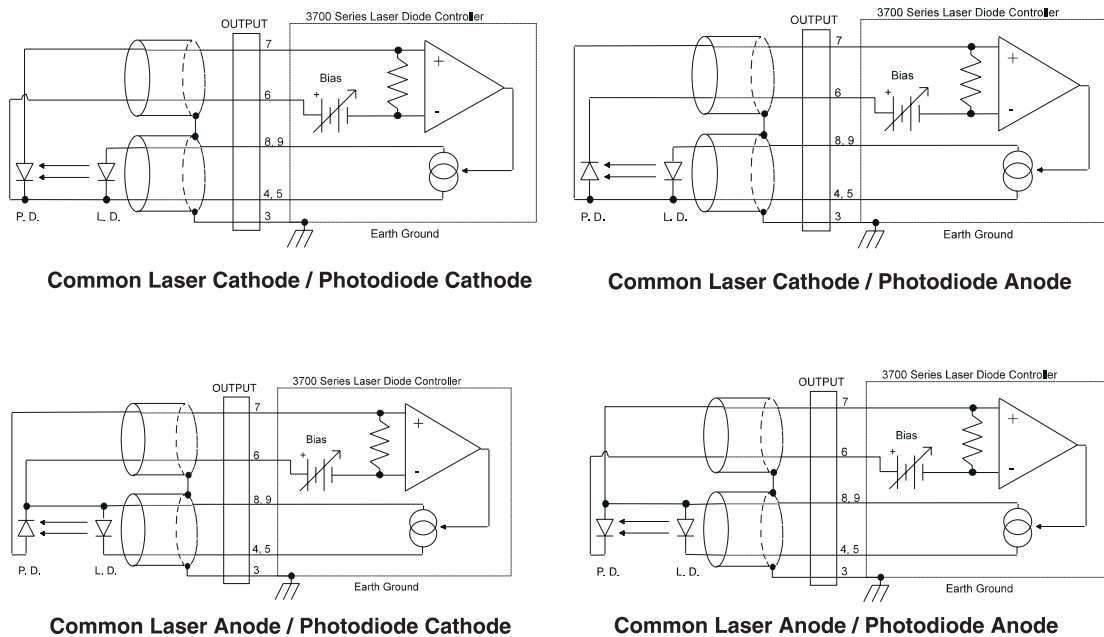

Figure 7. Possible configurations used to connect laser diodes and photodiodes to an ILX Lightwave precision current source or controller.

rent source that provides a low-bandwidth mode. When low-bandwidth mode is selected, ILX Lightwave current sources engage an output stage filter and use a slower control-loop bandwidth. This further reduces the magnitude of noise and transients on the output.

It is important to note that a precision current source is only one part of a laser protection plan. No instrument can protect against all conditions. The instrument itself cannot protect against ESD-related damage that occurs to the laser prior to connection, or transients that are radiated directly onto the laser or through the cabling (see “System Setup,” below). However, ILX Lightwave precision current sources and controllers offer the most advanced laser protection against the damage mechanisms mentioned above. ILX Lightwave current sources features include dou-

ble-shielded transformers, power line filters, clamping current limits, slow-start-up topologies, and other protection topologies. In addition, the ability of our current sources to suppress power line transients is measured against IEC 801-4 and IEC 801-5 line transient waveform standards.

Our own comparative testing and discussions with researchers have indicated that some products marketed for driving laser diodes are clearly not suitable for their intended purpose, even when laser protection claims are made. We strongly recommend that you thoroughly evaluate any laser driver for its ability to protect your laser diode.

Temperature Controllers

When considering laser protection, most researchers tend not to think about temperature control. Of course, many critical

laser diode parameters, including wavelength, threshold current, and efficiency, are highly dependent on junction temperature. So, for many applications, highly stable temperature control is desirable. Operating temperature also greatly affects the lifetime of a laser diode. As a rough estimate, lifetime is reduced by an order of magnitude for every 30°C rise in case temperature (Figure 8). It's usually desirable to operate the laser at as low a temperature as possible, depending on your application and laser type.

Simple passive heat sinks can be used to draw heat away from low-power laser diodes. High-power laser diode arrays usually require water cooling. If the application demands a high degree of stability, temperature control instruments that drive Peltier, or thermoelectric, modules to actively remove heat should

be used. For more information, refer to ILX Lightwave's Temperature Control Application Notes. (See References.)

If you use a temperature controller, be sure to set its current limit below the maximum rating of the TE module. To avoid oscillations, set the gain of the instrument feedback loop to match the thermal load. If you are not sure where to set the gain, start with a low gain, and gradually increase the gain until you achieve a quick settling time without significant overshoot. (ILX Lightwave temperature controllers with a "hybrid smart integrator" algorithm minimize this condition.)

We have recently evaluated several commercially-available laser mounts with TE modules that are unable to hold the laser at their specified low temperature rating for more than a short time. If heat sinking is not adequate to dissipate generated heat, the operating efficiency of thermoelectric modules is reduced, and large temperature drifts can result. This is not only frustrating, but puts the laser at risk as well. We suggest that you test your mount without a laser load (or with a "dummy" load) prior to actual use. ILX Lightwave heat sinks are tested to hold the specified low temperature indefinitely under normal conditions.

Chose a temperature controller with a high temperature limit (or thermistor resistance limit), and set the limit just above operating conditions. This will help protect against the thermal runaway condition mentioned above.

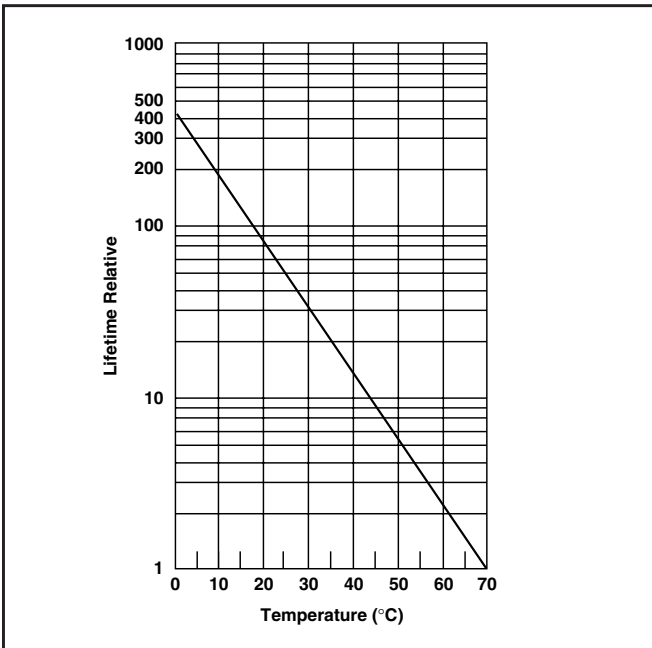

Figure 8. Laser lifetimes decrease dramatically with higher operating temperatures. Relative lifetimes are referenced to 70°C. (Ref. 22)

LEVEL II

System Setup (Mounting, Cables, and Grounding)

Choosing the right driver is imperative in ensuring a protected laser. But the instrument itself cannot protect against transients that are radiated directly onto the laser or through system cabling. To protect against these threats, careful consideration of interconnection must be made during system setup.

Here, we define “system setup” to encompass the diode mount and cabling in addition to the driver or controller. It also includes other test equipment connected to the system (e.g.,

function generator via bias-T network, thermoelectric coolers, or monitoring equipment such as oscilloscopes). When constructing a system, remember that the weakest link will

Overview of Recommendations — Level I

- ❑ Do not use a voltage source to drive your laser. At a minimum, select a current source with a shorting output, slow-start, independent clamping current limit, over-voltage protection, and proven transient suppression.
- ❑ Select a drive instrument with maximum current levels commensurate with the laser’s operating current. (Certain parameters scale with the maximum current of the instrument, including the level of power-line transient suppression.)
- ❑ Set current limit to appropriate levels, following the laser manufacturer’s recommendations (or to just above expected operating current, if the manufacturer does not specify maximum current). Use a power limit as well, if your instrumentation provides one.
- ❑ Operate your laser at the lowest temperature possible, depending on your application and laser type. Make sure your laser mount is capable of dissipating the heat generated by your laser without thermal runaway.

determine the relative strength of the system. This is especially true concerning radiated noise susceptibility.

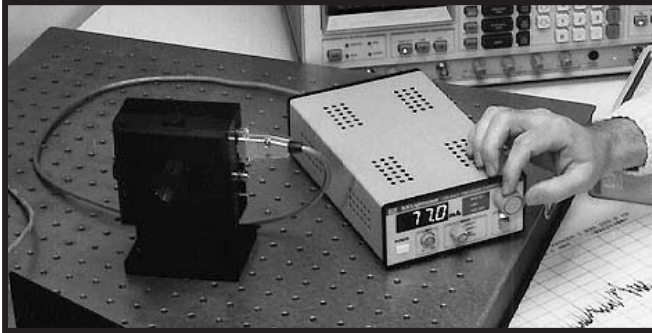

Unfortunately, the “ideal” system connections will change for different test setups and user needs, and system setup frequently requires some changing or “tweaking”. This section will aid in determining what is ideal for your situation by exploring the issues most commonly encountered in laser setups.

To isolate and eliminate electrical transients, we must first understand how these transients arise. It is best to start with a simple model. For our purposes, radiated transients can be considered as noise signals. The elements of our model are simply: 1) the source of noise, 2) coupling mechanism, and 3) receiver (Figure 9).

Typical noise sources include: transformers, fluorescent lights, FM radio stations, switching power supplies, high speed data communications channels, lightning, motorized positioning equipment, and other peripheral equipment. The receiver in our case is the laser diode. The coupling mechanism is usually the most difficult element to recognize. If all three elements are identified, a fix will usually become obvious. In many circumstances, the

cost associated with identifying all elements of transient coupling in your laboratory is impractical. But precautionary steps can be taken to prevent and eliminate the types of transients that are most common.

Grounding

Although system grounding will be discussed along with each element of the system, a thorough understanding of grounding will augment the following discussions on mounts, cables, and other test equipment.

Grounding Terminology

A discussion of “grounding” cannot be complete without a review of terminology. Be careful how you use the word “ground,” or more specifically, the “ground node”. Webster’s dictionary defines ground as “surface of the earth; or a conduction line between electrical equipment and the ground.” Interestingly, another definition for ground is: “to establish; to instruct in elementary principles — a basis or foundation (groundwork).” These definitions epitomize the confusion that’s usually associated with discussions of “ground” in electronic systems.

The first definition of ground can be clearly described by “earth ground,” and any connection to this node or potential is identified with a specific symbol. This “earth ground” is always at earth potential. The second definition of ground infers the zero-voltage plane (which is the reference for the electronic circuitry). This reference plane does not need to be (and in some instances should not be) connected to the earth ground.

To complicate matters further, there can be

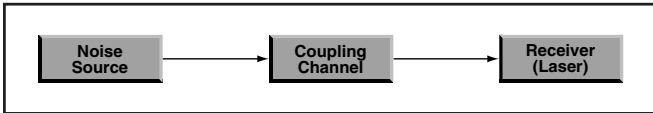

Figure 9. Typical noise path. All three elements are necessary to produce a problem.

more than one reference plane, depending on the requirements of the electronics within the system or setup. For such reference planes, we recommend specific descriptions along with the word “ground”. Descriptors such as “analog ground” and “digital ground” identify the functionality clearly. Finally, avoid using the word “ground” by itself, or where the word “return” more accurately conveys the function of the electrical node.

The word “node” refers to a single point, and connections to this single point should be observed. The system ground node in your schematic is undoubtedly the most important (although not the most exciting) node in the system. In practice, the system ground can rarely be implemented as a single point. Where greater demand for accuracy is needed, the amount of attention required by the ground node increases.

(Note that bus wire and PC board traces have a small, yet significant resistance that results in voltage changes along the ground trace. While this usually doesn’t pose a serious threat to the laser, it can cause unwanted errors and drift in your system.)

Grounding Considerations

Grounding is a topic that is simple in concept, but becomes complicated (and misunderstood) in practice. Most confusion arises from the fact that system elements are grounded for two reasons — 1) to determine the voltage

potential at which the laser operates (with respect to earth ground and other electronic equipment), and 2) to provide a return path for the device current. Keep these two functions in mind when connecting your system ground.

The first purpose of a ground system is to reference the diode with respect to earth ground. This is sometimes defined for you. Often, the heat sink requirements will dictate where the earth potential connection is made. (Mounts are usually grounded.) Another example is a modulated laser with the anode connected to the case. In this configuration, your modulating source (i.e., microwave generator) connects the anode to earth ground. Since the anode is at earth potential, no other node in your electronic system should be connected to earth. (Otherwise, you may short your diode, or worse, short a current-sensing element.)

Tests conducted at ILX Lightwave have shown that earth-ground location can profoundly affect the magnitude of transients coupled onto the system. When earth grounding your system, avoid ground loops. (See sidebar, pg.12) A single point ground node (with only one physical connection point) is the best solution. Unfortunately, this is usually not practical. If multiple grounding cannot be avoided, attention must be paid to the ground current flowing in the loop.

If you choose to locate the ground potential at an unusual place, give yourself a reminder, such as a Post-it note. Otherwise, you may inadvertently pose a shock hazard to both yourself and your laser.

The second function of a common ground is

What is a “Ground loop”?

...That’s probably one of the least asked but most frequently considered questions in system design. The term “ground loop” is often used when trying to explain poorly understood setup problems, which simply adds to the confusion.

In short, a ground loop is a closed path, or loop, of electrical conductor. Electrical fields that intersect a loop will induce a current in the loop. (The fact that the loop’s electrical potential is that of the system reference plane makes little difference to the electric field.) More specifically, a ground loop is a conductor loop created by the specific connection of the various ground points in an electrical system. Any circuit with many connections on a single node will create a loop. The bigger the loop, the more noise energy that can be coupled into the loop. Furthermore, once the noise couples onto the ground, it can easily couple everywhere in the system.

The signal ground node in most circuits normally has the most connections. This increases the chances of large conductor loops. The earth ground node may also have common connections to other instruments that are not intended to be part of your system. Inadvertent connection to these conductors provides additional chances of loops and induced noise.

Not surprisingly, ground loops are a common occurrence in electronic systems. The best solution to ground loop problems is to simply break the loop. Unfortunately, the hardest part is identifying the ground loops. In those cases when the loop is unavoidable, then reduction of loop area is advisable.

to provide a current return path for system current flow. This is usually where problems associated with “poor ground” arise. Avoid using the laser return path as a return for other circuits as well.

Even if you are using ILX Lightwave mounts and cables in a standard configuration, we strongly recommend that you sketch a simple schematic of your setup, with a focus on ground return paths. This schematic is a tool that will help identify critical ground connections and potential noise problems prior to connection, and may also payoff while troubleshooting system interference. The schematic will help define voltage reference planes in the

system and identify the current return paths. Ideally, each wire should be identified with some associated series resistance and inductance. The schematic should also include wire lengths and other details of the physical setup that may affect transient coupling.

A schematic of a test setup with poor grounding is shown in Figure 10a. Review of this schematic points to some system connection problems. Changing the connections to that shown in Figure 10b will result in greater immunity to radiated transients and avoid problems that can be caused by ground loops.

The actual implementation of ground con-

nections you make will be a compromise between conflicting requirements. On one hand, ground loops (and alternate current return paths) should be avoided. On the other hand, low inductance, high-frequency grounds are needed to drain fast transients*.

Your specific application and laboratory environment will dictate choices of system configuration. If you are mainly concerned with high frequency noise, then low-inductance multiple ground connections are needed. If low-frequency noise (50/60 Hz) is coupling into your system, a single-point ground connection and isolated system elements may be preferable. In most systems, both noise sources are present. In these cases, careful control of ground connections will reduce return paths while maintaining good high-frequency ground connections.

Through our own evaluations, we have learned that grounding strategies vary among instrumentation manufacturers in both implementation and effectiveness. It is wise to become familiar with the manufacturers' recommended procedures.

ILX Lightwave current sources employ a floating output to accommodate a variety of laser configurations and systems. This also reduces the possibility of line transient damage and helps avoid ground loops. If possible, it's best to leave the laser diode floating

** A quick way to test your high-frequency ground is to place your hand on the earth ground at various points along the ground path. If there is little or no change in the system operation, you can assume that the high-frequency ground is sufficient. If touching the ground causes a change (i.e., increased noise), your high-frequency grounding system could be improved.*

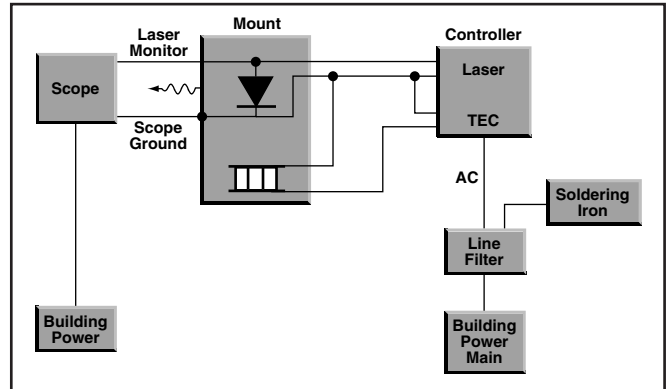

Figure 10a. Schematic of a poor system setup. Note the large ground loop formed by the laser instrument and oscilloscope.

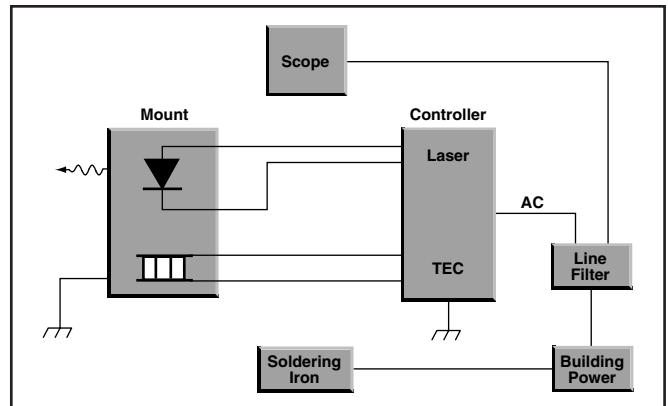

Figure 10b. Ideal system setup with isolated laser. Ground loops have been eliminated.

with respect to earth ground. (Figure 10b) Nonetheless, some testing situations require the laser diode be earth-grounded. In these cases, at least try to reduce the ground loop area and impedance as much as possible. Keeping the controller in close proximity to the diode will help. Providing a good (low inductance) connection to earth ground from both the mount and the controller will also help.

Laser Mounts

Laser diode mounts perform the seemingly innocuous task of providing a fixture (and usu-

ally heat sinking) for a laser diode. But certain considerations must be made to ensure a safe environment for your laser.

Obviously, when selecting or fabricating a laser diode mount, one must first consider the diode package. There are two major packaging styles (in addition to many special varieties). Window-can style laser packages are often used in free space (non-fiber-coupled) applications (Figure 11). The package (can) of the laser is usually connected to either the laser anode or cathode. The mount configuration determines whether the case (and therefore diode) is referenced to earth ground.

If possible, the package should be left isolated from earth ground. This allows more freedom of connection and will usually reduce the likelihood of ground loops and interference. ILX Lightwave mounts for window-can lasers allow the option of isolating or earth grounding the laser package. If your mount does not allow for isolation, and the case is earth-grounded, then the mount-to-ground connection should be a very good RF ground (very low inductance). Connection directly to power line ground (the round prong on the AC plug) is the minimum required. Ideally, you should connect the mount directly to earth ground (through a metal rod), use wide braid wire to reduce inductance, and/or keep cable lengths as short as possible.

Fiber-pigtailed telecom lasers, usually encased in DIL (dual-in-line) or Butterfly packages are also quite common. In these packages, the case is usually connected to the laser (typically the anode). Often, these lasers are modulated at high frequencies and the

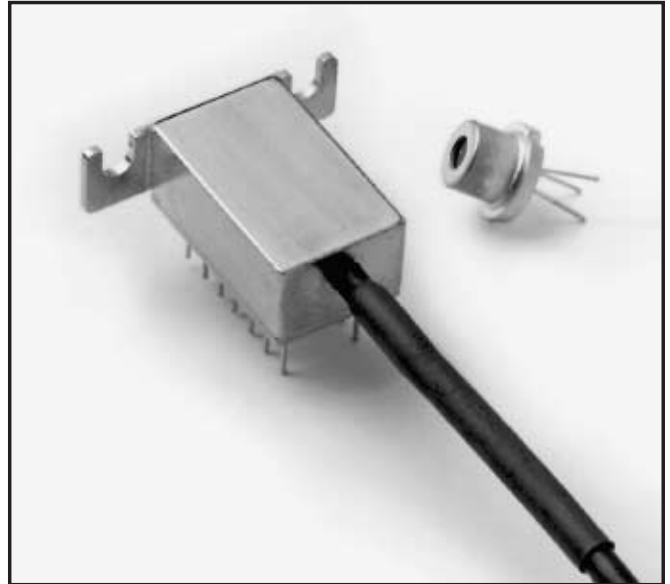

Figure 11. Fiber-pigtailed dual-in-line (left) and window-can laser packages are commonly used.

package must be earth grounded. In these situations, follow the guidelines above for grounded lasers. In addition, the grounding of other equipment (such as function generators and oscilloscopes) should be made as close to the mount ground as possible to reduce ground-loop area. Avoid using any unnecessary equipment on the same power ground as the diode mount.

When working with an unpackaged laser die, or package styles other than the types mentioned above, it is important to understand any special mounting constraints. Grounding guidelines identified above generally apply, however.

It is essential that your laser mount also suppresses high-frequency noise. If the mount ground is not sufficient, or the radiation environment is extremely harsh, the mount itself can act as an antenna and pick up radiated signals, which will induce currents in the

case node of the laser diode. Attention to ground configuration will normally improve these problems. If the radiation source can be identified, a grounded shield (sheet or screen of any conducting metal) can be placed between the source and the mount to reduce the field strength.

Unfortunately, thermoelectric cooler modules, common in laser mounts, can act as a capacitor between the case connection (heat sink) and the laser. Noise on the temperature control instrument can be coupled through this capacitance. Choose a low-noise, filtered TE controller to avoid this problem.

Also note that if low frequency (50/60 Hz) noise is a problem, one cause may be magnetic coupling. If a transformer is near by, then any cables running through the magnetic field of the transformer will carry an induced current. Magnetic coupling can be difficult to reduce since normal shielding does not affect the magnetic field. To attenuate magnetic fields, high permeability metals must be used. These can be expensive. A more cost-effective alternative is to shield the transformer or source of the magnetic field.

Cabling & Shielding

Since most laser diodes have a very low tolerance for reverse current, most users are careful to observe the proper polarity when connecting their laser diode to a current source. (If there's any question about polarity, an LED makes an inexpensive polarity tester that will light if the polarity is correct.)

Other, less obvious dangers of cabling can be just as disastrous, but are easily overlooked.

Loose Connections

A cable connection that is intermittent, or has a contact that's bouncing during connection, poses a threat to the laser. Laser drivers see this break as a higher impedance load, and try to drive harder. Ensure that the driver output is turned off prior to connecting your laser diode. Fasten all cables, and make sure cable connections and solder joints are robust, prior to turning the instrument output on. Avoid draping cables across your work area. Secure current source cables to your bench or optical table to avoid bumping them (but don't "bundle" current source cables with other instrument cables in your lab). Don't attempt to "multiplex" your current source to multiple loads with an external switch or relay.

Twisted Pair Cable

This type of wire is fairly common in electronic equipment, and is preferred in long cable runs. Twisted pair helps reduce low-frequency noise that is otherwise inductively coupled into the signal conductors. (This is because twisting the wire effectively reduces the loop area and therefore the inductive term in the coupling equation.) Unfortunately for twisted pair to have any effect on capacitively coupled noise, a balanced-line receiver is needed. Since this is not the case for laser diode applications, twisted pair cables offers no reduction for noise that is capacitively coupled into the signal wires. A shield is also needed.

Cable Shielding

Our studies of laboratory transients have shown that, depending on the characteristics of the transient, a surprisingly large amount of energy can be coupled directly onto the

current-carrying cable, even when the cable includes a shield. In many cases a shield is present, but its effectiveness is limited by improper shield termination. Cable shielding is an area of concern that is often misunderstood, yet is imperative in minimizing risk of laser damage.

A shield on a cable serves to drain electrical fields through a low-impedance path to earth ground, restricting radiation of energy from the internal wires. More importantly, it also prevents other electrical fields in the lab from coupling onto the wires.

To illustrate how an unshielded cable can act as a transient coupling mechanism, the barbell model is useful (Figure 12). Here, it is assumed that the diode mount and laser driver are adequately shielded. A good cable shield then completes the “barbell,” which encloses the drive electronics, laser diode, and laser connection wires in a Faraday Cage. Any breaks in the shield will cause “leaks,” which will allow RF energy into the system. Proper termination of the cable shield is therefore critical.

Do not use the shield as a current-carrying conductor. Rather, terminate the shield at both ends to a low-inductance earth ground. If this sets up a ground loop and you observe significant low frequency (50/60 Hz) noise, terminate one end (preferably the mount) to earth ground through a few-hundred picofarad capacitor. This will break the loop for low frequency noise, while preserving the high frequency connection to earth ground to drain radiated transients.

Ideally, the shield itself should be a braid with as much coverage as possible (within the practical constraints of cable flexibility and diameter). A metal foil shield can be used, but the seam of the foil tends to leak high-frequency energy, and is not as effective against transients.

ILX Lightwave Cables

The proper cable will depend on both the system setup and the noise environment of the system. Of course, these factors will vary greatly among applications. Based on findings from laboratory testing at ILX Lightwave, we have created a unique twisted-pair cable with braided outer shield. This cable has been designed to provide the best possible rejection of most transient noise signals.

As of February 1996, this type of cable is available from ILX Lightwave as our standard current source cable. Although every situation is different, we feel that this cable provides the

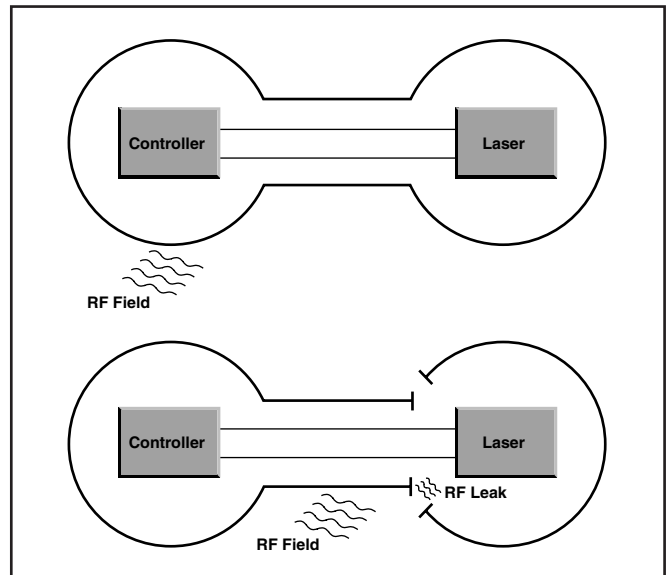

Figure 12. System shielding represented with the “barbell” model. Breaks in the shield may allow transients to “leak.” (Refs. 10, 11)

best protection over the widest range of laboratory conditions. Contact an ILX Lightwave representative for more information.

LEVEL III Lab Environment

Whether a laser is damaged by a power-line transient depends on several factors, including the magnitude of the transient, the temporal qualities of the transient, and the sensitivity of the laser. These factors vary with the specific laser and the particulars of your laboratory environment.

Planning a lab environment to minimize the quantity and magnitude of electrical transients

is highly recommended. We realize that it's impractical to eliminate all sources of transients. However, there are important implications for lab layout and organization that are actually quite simple to implement. When in doubt, it is always best to take the most conservative approach.

Overview of Recommendations — Level II

- ❑ Grounding is a complex issue, and is application dependent. Familiarize yourself with the terminology and function of ground nodes. Avoid using the diode wires as return paths for other currents. Avoid ground loops. When using ILX Lightwave instruments, it's best to leave the laser diode floating with respect to earth ground.
- ❑ Use appropriately shielded cabling to reduce coupling of radiated transients. (As of February 1996, ILX Lightwave's standard current source cables are a unique braid-shielded twisted pair. Contact an ILX Lightwave representative for more details.) Use proper cable termination.
- ❑ Make sure that all cables to the laser diode are securely fastened. Do not "bundle" current source cables with other cables in your laboratory.

Electrical Fast Transients

Transient suppression techniques have tra-

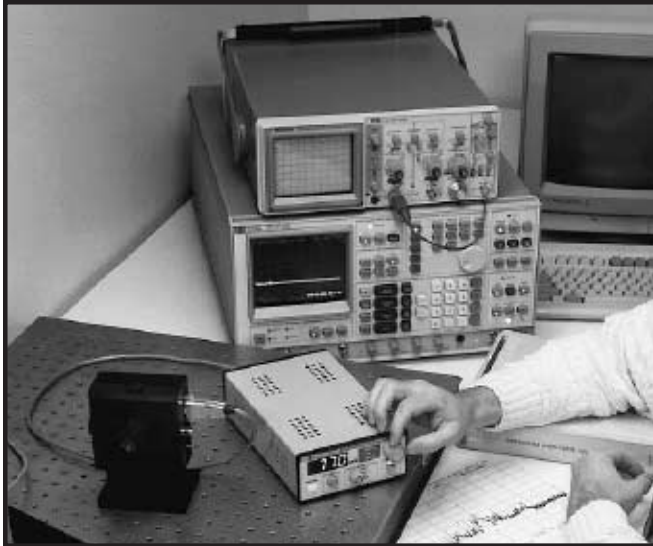

ditionally focused on transients caused by lightning strikes in close proximity to the laboratory (or near power lines entering the lab). A second class of line transient that has become pervasive is the Electrical Fast Transient (EFT). EFTs are very fast transients (typically tens of nanoseconds in duration) that tend to radiate and couple into other equipment due to their high frequency content. (See sidebar, pg.18)

In most labs, EFTs are caused by equipment that requires large power line surge currents (e.g., soldering irons and most motor and compressor equipment). Equipment designed with switching power supplies (virtually all computers) also generate EFTs. Again, EFTs are typically much faster than lightning or power surges and, compared to surge transients, have a greater tendency to radiate throughout the lab.

As mentioned, instrumentation should be

designed with the maximum amount of transient suppression practical, and the use of proper grounding and appropriately shielded cabling can help suppress radiated transients. Still, high frequency transients have a way of finding their way past even the best defenses. We strongly urge you to isolate sources of EFT spikes as much as possible.

Radiated Transients

Laser diodes are sensitive to all sources and types of electromagnetic interference (EMI), including EFTs. As one laser manufacturer points out, "Laser chips can be damaged or destroyed by induction voltages that can occur near equipment that emits high-frequency EMI. Avoid using laser chips near fluorescent lamps or other external sources of EMI emissions." (Ref. 4)

In some environments, where power supplies or industrial loads are switched on the line, high levels of radiated EMI transients may be present. Note that high voltage supplies for gas lasers and excimer lasers are notorious for generating large amounts of EMI. This type of interference can be a problem even when the source is located in another laboratory.

Ideally, you should plan the layout of your laboratory to maximize physical separation between sources of EMI and your laser diode. Again, cables should be properly shielded, and securely connected to the drive instrumentation and the laser. In addition, it is a good idea to keep laser cables as far as possible from other instrument cables. Avoid "bundling" instrument power cords and cables together with the laser drive cable. Otherwise, noise and transients from other instruments

Radiated Transients: How are they Coupled?

Coupling mechanisms are the paths by which energy is transferred from a noise source into receiving circuits. The most obvious example of a coupling mechanism is your TV antenna. Unfortunately, coupling is not always desired. An example of this is the pickup of a neighbor's blender or vacuum cleaner during your favorite show.

The physical laws by which noise travels through space and is coupled onto a receiving conductor were described by James Clerk Maxwell (1831-1879). For our purposes, a simplified explanation will provide an overview of the mechanisms described by Maxwell.

One mechanism involves the coupling of the electric field from a radiating source to a receiving conductor. This can be modeled as a capacitance between the noise source and the receiver. The amount of energy present in the receiver depends on the coupling capacitance and the receiver's capacitance to earth ground. This sets up an impedance divider circuit. For this type of coupling, the parameters that affect the capacitance (i.e., area and separation of the conductors) will affect the coupling. (Ref.8, p.30)

At higher frequencies, electric fields are the most predominant coupling mechanism. Effective containment of these fields can be accomplished by metal shields terminated to ground. (Note that the ground termination must be low impedance at the noise frequency of interest.) Other ways to reduce the capacitive coupling are separation of the conductors. This reduces the capacitive term in the coupling model.

A second mechanism by which transients are coupled onto a receiving conductor is through their magnetic field. This can be modeled as a mutual inductance between the noise source and the receiving conductor. For this case the mutual inductance is dependent on the induced field strength, magnetic properties of the medium, and area of the receiver conducting loop. (Ref.8, p.37)

Inductive coupling is most common at lower frequencies (especially 50/60 Hz). This noise coupling can only be reduced by containing the magnetic field or reducing of the loop area. Since most metals have very little effect on the magnetic field strength, special (higher cost) materials with high permeability must be used to effectively contain the magnetic field. Minimizing the loop area of the receiving conductor is a more cost effective way to reduce inductive coupling.

may easily radiate directly onto the laser cable.

AC Power Line Isolation

Most manufacturers claim that their current sources include adequate transient suppression. Unfortunately, their transient specifications do not indicate the level of input transients or other test conditions.

At ILX Lightwave, we test our current sources for transient attenuation against IEC-standard 1000 V transients, and strive to provide our customers with as much information as possible. (The IEC standards committee has defined standard surge and EFT profiles and

levels to model typical lab environments. We have used these standards to define a repeatable testing standard that is applied to all our instruments.)

The testing done at ILX Lightwave is, to our knowledge, the most extensive to date on surge and EFT line noise with respect to laser diodes. (For more information, request ILX Technical Standard LDC-00196, "Measuring Transient Suppression of Laser Diode Drivers.")

In comparisons with other manufacturers' products, ILX Lightwave current sources have extremely low transient feedthrough (Table

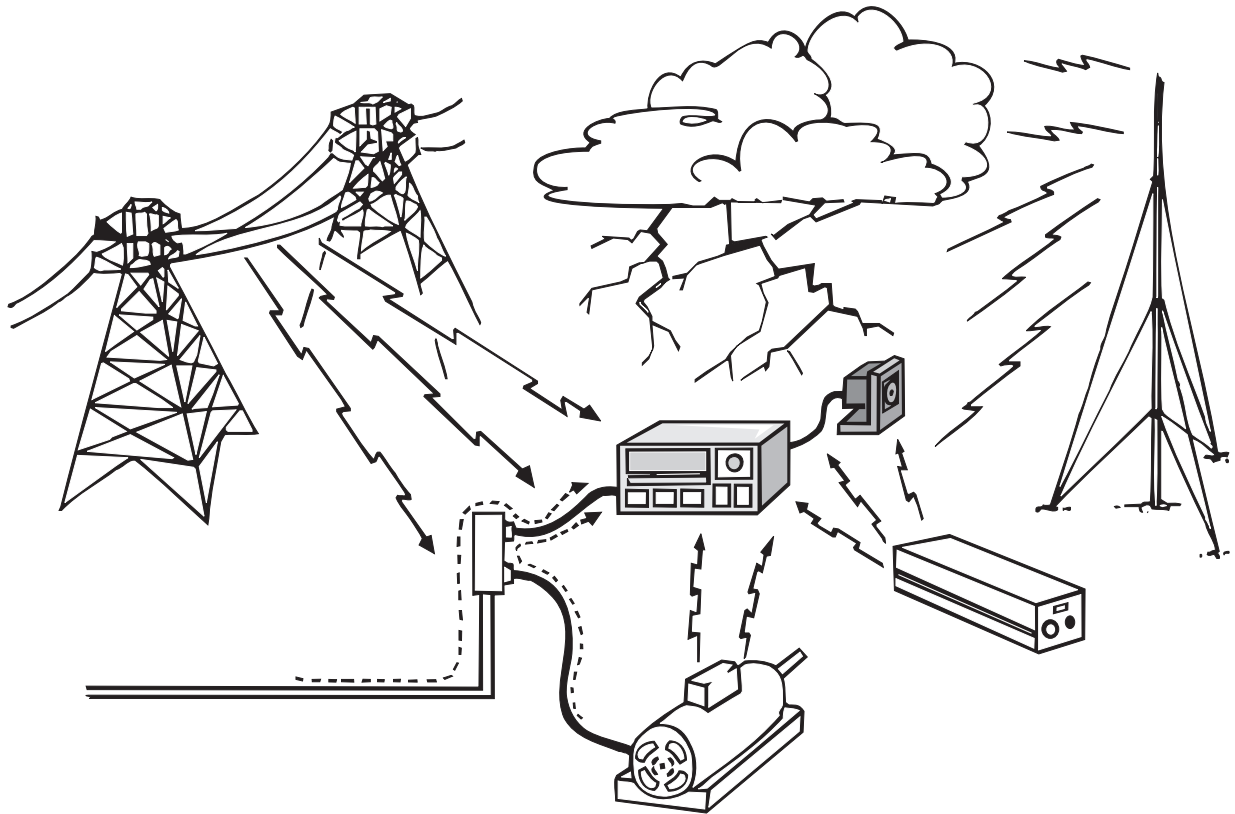

Even seemingly innocent lab equipment such as bench power supplies and other lasers can generate high levels of EMI. Take appropriate precautions.

1). In most cases, when proper grounding is used, ILX Lightwave current sources provide excellent transient suppression. However, when very severe line transients are a problem, there is no substitute for multiple stages of protection, such as found when an isolation transformer is used with a well-designed current source.

If industrial loads are switched in or near your laboratory, use isolation transformers and/or a surge-suppressor power strip. We have found that an Extreme Isolation Transformer (EIT) provides the best protection against transient feedthrough. Furthermore, avoid using laboratory power supplies, soldering irons, or other electronic instruments that use switching power supplies on the same power strip as your laser current source. (“Surge-suppression” power strips are often designed to isolate the AC main from your equipment, but are not necessarily effective in isolating instruments from one another.) If you must use a common line with such equipment, isolate your laser driver with a separate surge pro-

jector, and keep these instruments as far as possible from the laser and current-carrying cables.

LEVEL IV Handling & Human Contact

Proper handling is perhaps the most overlooked aspects of laser protection. Yet careful storage, transport, and mounting of laser diodes is nothing less than critical in ensuring optimum laser lifetimes.

Electrostatic Discharge

Laser diodes, like most semiconductor devices, can be easily damaged or destroyed by inadvertent electrostatic discharges (ESD). In fact, it’s been suggested that ESD is the single leading cause of premature laser diode failure. As one laser manufacturer mentioned, “Most researchers will go through at least one or two lasers before realizing they have not taken appropriate static precautions.”

ESD in your laboratory can be difficult to pin-

Overview of Recommendations — Level III

- ❑ Plan your laboratory to maximize physical separation between sources of EMI and your laser diode. Keep laser cables as far as possible from other instrument cables, and don’t “bundle” power cords and cables together.
- ❑ If industrial loads are switched in or near your laboratory, use isolation transformers and/or a surge-suppressor power strip with your laser current source.
- ❑ Isolate your laser current driver with its own surge protector when using a common line with laboratory power supplies, soldering irons, or other electronic instruments. Do not use such devices on the same surge-protector power strip as your laser current source.

point, since laser diodes can be damaged by voltages that are too small to feel through



your skin. Human skin is only sensitive to 3000V or more, yet empirical evidence has shown that commercially available InGaAsP and AlGaAs laser diodes can be damaged by ESD voltages as low as 1200V. (Figure 13) Just because you don't hear or feel a static spark, don't assume there isn't a dangerous ESD discharge.

As with all semiconductor devices, ESD has the potential for latent damage in laser diodes. In other words, ESD may simply weaken the device without any immediate symptoms. The static discharge breaks down the P-N junction in an area outside the optical cavity. During normal use, these defects propagate into the laser cavity over time. The resulting degradation in performance may appear long after the initial damage takes place. (Ref. 5) When this "latent failure" finally occurs, it may be attributed to other causes. Ignored by the user, the ESD problem remains unchecked.

Proper discipline in following an ESD con-

trol program cannot be understated. A static-free environment is mandatory.

The elimination of all potential ESD risks is straightforward in theory, but can be difficult

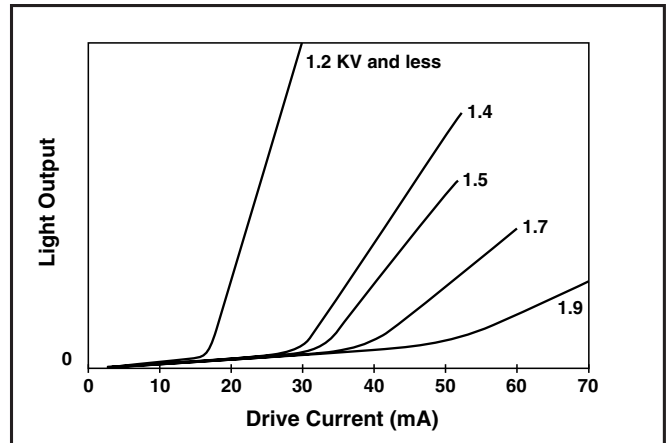

Figure 13. Forward L/I Characteristics of InGaAsP laser after reverse-biased ESD stressing at various voltages. Note the abrupt onset of failure at 1400 V. (Ref. 7)

to achieve. In facilities where laser diodes (or other static-sensitive devices) are handled regularly, an ESD audit conducted by an independent certified consultant is recommended. (Ref. 16) In general, though, there are four basic "golden rules" that must always be followed:

1. Whenever handling unprotected devices, wear a protective wrist strap designed to drain built-up electric charges safely to ground. Choose a secure, but comfortable strap with a 1 M Ω series resistor. Properly ground tweezers, soldering irons, and other tools as well.
2. Place unprotected lasers only on certified, static dissipative work surfaces.
3. When transporting, storing, or not working on your laser, completely enclose it in a conductive, shielded material. Short the pins when not in use by inserting them

into conductive foam. Spring-like shunting devices that are mounted to the laser and automatically short the pins are highly recommended. (Ref. 17)

4. Keep all charge-generating materials at least 12" away from unprotected devices since the device can become charged inductively.

In problem areas, anti-static floor coverings and ionized air blowers are also recommended. Wear clothing made of materials resistant to charge creation. (Cotton is best, wool is fair, and synthetics are poor.)

Static protection products should be examined on a regular basis for effectiveness, as they may degrade over time. Remember, taking preventative measures against ESD damage is particularly important since static damage may not show up until after the laser diode has been used for some time.

Other Handling Precautions

The window of TO-packages is usually quite thin (typically about $\frac{1}{4}$ mm). Do not push on the window when inserting the laser diode into a mount socket. Wear anti-static gloves or finger cots, and push the device into place by pressing on the base of the package.

Store the laser diode in its shipping container when not in use. This not only helps protect against ESD, but also keeps dust and dirt off the laser window. If the window becomes dirty, clean it with a lens tissue wet with reagent-grade acetone or propanol. (Ref. 2)

When handling open-heat-sink laser diodes, exercise extreme caution to avoid mechanical

contact on the laser chip or contamination of the facet. To clean particles from the facet, use a gentle stream of dry nitrogen gas. Handle the device with tweezers to avoid contamination with skin oils. Do not use thermal grease when mounting these types of lasers to a heatsink, as grease can creep and eventually contaminate the laser. (Thermal grease is acceptable with sealed packages.) If the facet becomes contaminated with an oil-based substance, follow the manufacturer's recommendation for cleaning. Use caution if

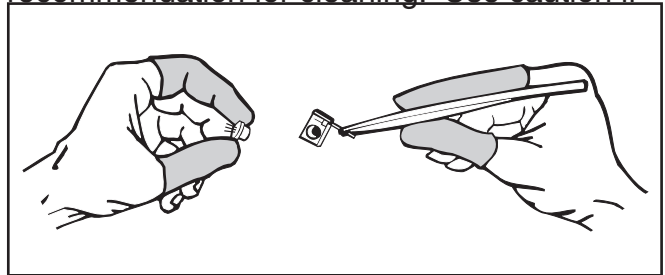

Figure 14. Anti-static gloves or finger cots should be worn when handling laser diodes. Do not touch the facet of open heatsink lasers. (Ref. 2)

attempting to couple an optical fiber to the laser, as contact of the fiber against the facet may cause damage.

Improper soldering practices are a common cause of laser overheating. Most manufacturers provide detailed instructions for soldering, including maximum solder temperatures and times — usually less than 10 seconds at 250 to 300°C.

Do not carry or handle any laser diode by the pins. Pins in many laser packages are insulated from the case with a glass seal. Be careful when installing your laser to avoid over bending the pins which can break the seal.

Summary

Laser diodes are extremely sensitive to electro-static discharge and current spikes (transients). Damage can result in reduced output power, shift in threshold current, changes in beam divergence, and ultimately failure to lase (LED-like output only).

This application note has outlined precautions and procedures that you can take to protect your laser diode. A summarized checklist of specific actions follows. We strongly urge you to follow these recommendations and use the checklist to minimize your risk of laser damage.

We at ILX Lightwave encourage your safe and successful laser diode use. If you have any questions, please contact your ILX Lightwave representative.

LEVEL I Drive Instrumentation

- ❑ Do not use a voltage source to drive your laser. At a minimum, select a current source with a shorting output, slow-start, independent clamping current limit, over-voltage protection, and proven transient suppression.
- ❑ Select a drive instrument with maximum current levels commensurate with the laser's operating current. (Certain parameters scale with the maximum current of the instrument, including the level of power-line transient suppression.)
- ❑ Set current limit to just above expected operating current. Use a power limit as well, if your instrumentation provides one.
- ❑ Operate your laser at the lowest temperature possible, depending on your application and laser type. Make sure your laser mount is capable of dissipating the heat generated by your laser without thermal runaway.

LEVEL II System Setup

- ❑ Grounding is complex issue, and is application dependent. Familiarize yourself with the terminology and function of ground nodes. Avoid using the diode wires as return paths for other currents. Avoid ground loops. When using ILX Lightwave

Overview of Recommendations — Level IV

- ❑ ESD is the primary cause of premature laser failure. As a minimum, use anti-static wrist straps (grounded with 1 M Ω resistor), grounded soldering irons, and grounded work areas. Ionized air blowers and anti-static floor coverings are also recommended.
- ❑ Laser diode leads should be shorted whenever the laser is transported or stored. (ILX Lightwave current source outputs are automatically shorted when not in use.) Place unprotected lasers only on static dissipative work surfaces, and keep all charge-generating materials away from your laser.
- ❑ Exercise caution when handling laser diodes. Wear anti-static gloves, and clean your laser according to the manufacturer's recommendations.

Laser Protection Checklist

All of the following precautions must be taken to ensure the complete protection of your laser diode and to minimize the risk of damage:

- instruments, it's best to leave the laser diode floating with respect to earth ground.
- Use appropriately shielded cabling to reduce coupling of radiated transients. (As of February 1996, ILX Lightwave's standard current source cables are a unique braid-shielded twisted pair. Contact an ILX Lightwave representative for more details.) Use proper cable termination.
- Make sure that all cables to the laser diode are securely fastened. Do not "bundle" current source cables with other cables in your laboratory.
- not in use.) Place unprotected lasers only on static dissipative work surfaces, and keep all charge-generating materials away from your laser.
- Exercise caution when handling laser diodes. Wear anti-static gloves, and clean your laser according to the manufacturer's recommendations.

LEVEL III Lab Environment

- Plan your laboratory to maximize physical separation between sources of EMI and your laser diode. Keep laser cables as far as possible from other instrument cables.
- If industrial loads are switched in or near your laboratory, use isolation transformers and/or a surge-suppressor power strip with your laser current source.
- Isolate your laser current driver with its own surge protector when using a common line with laboratory power supplies, soldering irons, or other electronic instruments. Do not use such devices on the same surge-protector power strip as your laser current source.

LEVEL IV Handling & ESD Protection

- ESD is considered the primary cause of premature laser failure. As a minimum, use antistatic wrist straps (grounded with 1 M Ω resistor) grounded soldering irons, and grounded work areas. Ionized air blowers and anti-static floor coverings are also recommended.
- Laser diode leads should be shorted whenever the laser is transported or stored. (ILX Lightwave current source outputs are automatically shorted when

References:

1. Heterostructure Lasers, Volume 1&2. H. Casey and M. Panish.
2. Laser Diode Operator's Manual & Technical Notes. 1994, SDL Inc.
3. 1993 Product Guide. 1993, Lasertron Corporation.
4. 95-96 Laser Diode Data Book. 1995, Rohm Corporation
5. S. P. Sim, M. J. Robertson, R.G. Plumb, "Catastrophic and latent damage in GaAlAs lasers caused by electrical transients," Journal of Applied Physics, 55, 3950-5 (June, 1984).
6. D. A. Shaw, P.R. Thornton, "Catastrophic Degradation in GaAs Laser Diodes," Solid State Electronics, 13, 919-24 (1970).
7. L. F. DeChiaro, B. A. Unger, "Degradation in InGaAsP Semiconductor Lasers Resulting from Human Model ESD," 1991 EOS/ESD Symposium Proceedings.
8. Noise Reduction Techniques In Electronic Systems. H. Ott., 1976, John Wiley & Sons.
9. Controlling Radiated Emissions by Design. M. Mardiguian, 1992, Van Nostrand Reinhold.
10. E. F. Vance, F. M. Tesche, "Shielding Topology in Lightning Transient Control," NASA Conference Publication 2128 FAA-RD-80-30.
11. D. L. Sweeney, M. Sweeney, "Mitigating Excessive Emissions," ITEM '89
12. D. Gerke, B. Kimmel, "Grounding: Facts and Fallacies," EDN Supplement, 39, 2, 91-100. (January 20, 1994).
13. D. Gerke, B. Kimmel, "Cables and Connectors: How to Stop the EMI Leaks," EDN Supplement, 39, 2, 71-77 (January 20, 1994).
14. W. G. Olsen, D. J. Hodgson, B. Bowen, "Measuring Transient Suppression of Laser Diode Drivers," Technical Standard TS-00196, 1995 ILX Lightwave Corp.
15. D. E. Frank, "ESD phenomenon and effect on electronic parts," Douglas Paper 7072, McDonnell Douglas Corp., April, 1981.
16. R. Peirce, "ESD Liability Analysis," ESD Technical Services," August, 1995
17. D. Cronin, "CRO-BAR: A New Technique for ESD Protection," EMC Test & Design, January, 1993.
18. J. R. Huntsman, D.M. Yenni, Jr., "Test Methods for Static Control Products," 1982 3M Static & Electromagnetic Control Division.
19. D. M. Yenni, Jr., J. R. Huntsman, "Quality Through Static Damage Prevention," 1981 3M Static & Electromagnetic Control Division.
20. D. Stanisich, B. Bowen, "Laser Diode Protection Strategies," 1988 ILX Lightwave Corp.
21. D. J. Hodgson, "Clamping Limit of an LDX-3525 Precision Current Source," Technical Note, 1995 ILX Lightwave Corp.
22. Physics of Semiconductor Laser Devices., G. Thompson, John Wiley & Sons, 1980, 28-29.

For more information about temperature control, request the following ILX Lightwave Applications Notes:

ILX Application Notes #1, "Controlling Temperatures of Diode Lasers and Detectors Thermoelectrically."

ILX Application Notes #2, "Selecting and Using Thermistors for Temperature Control."

ILX Application Notes #4, "Thermistor Calibration and the Steinhart-Hart Equation."

Special Thanks to Roger Peirce, President of ESD Technical Services, Langhorne, PA. (215) 364-1050. Formerly a research scientist at AT&T Bell Laboratories, Roger is an expert in the area of ESD prevention.

© Copyright ILX Lightwave Corp., 1996.

For additional copies, please contact your ILX Lightwave representative.

ILX Lightwave Corporation was founded in 1986 as a privately held, venture financed manufacturer of photonic test and measurement instruments. Our commitment to you is to provide the highest quality instrumentation and technical support available.

For application assistance or additional information on our products or services you can contact us at:

ILX Lightwave Corporation
P.O. Box 6310
Bozeman, MT 59771-6310

Toll Free: 1-800-459-9459 in the U.S. and Canada

Phone: 406-586-1244

Fax: 406-586-9405

Email: sales@ilxlightwave.com

Log on to our website at **www.ilxlightwave.com** and quickly get information on all of our products, receive technical support and download Technical Notes, Application Notes, LabVIEW® drivers and other information.

Photonic Test & Measurement Instrumentation